

# DESIGN NOTES

## Versatile Micropower Voltage Reference Provides Resistor Programmable Output from 0.4V to 18V – Design Note 351

Jon Munson

### Introduction

Voltage reference integrated circuits are widely used to establish accurate and stable voltages in analog circuits. While calibration-grade references are based on buried Zener diode technology (or even more exotic methods), the ubiquitous “band-gap” technique is the workhorse of the general purpose reference offerings. Band-gap references have historically offered fixed 1.2V to 10V outputs, along with a few adjustable models. The highly miniaturized LT<sup>®</sup>6650 extends the scope of band-gap technology to offer the guaranteed ability to operate on a single supply down to 1.4V in ThinSOT<sup>™</sup> packaging and with an output voltage as low as 0.4V. The LT6650 may also be powered by or produce reference voltages up to 18V and operate in either shunt mode or in a low dropout (LDO) series mode. The LT6650 is easy to use, sporting micropower dissipation (about 6 $\mu$ A of quiescent current) and simple 2-resistor voltage programming.

### Easy Output Voltage Programming

Figure 1 shows the basic connection for developing a fixed 400mV  $\pm$ 1% reference voltage from any supply voltage in the range of 1.4V to 18V. The internal noninverting op amp input port is always driven by a 400mV band-gap derived signal and the inverting op amp port is pinned out as a user connection. In this circuit, the op amp is simply provided with 100% negative feedback, thereby forming a unity-gain buffer for the reference source.

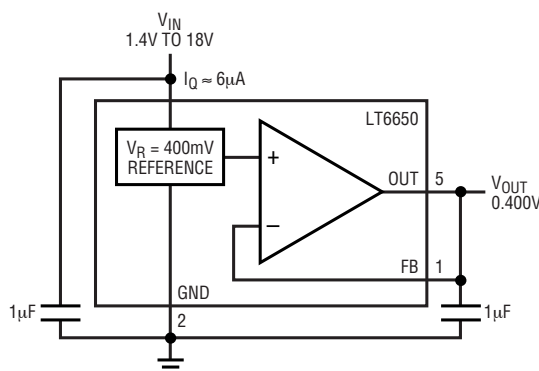

Figure 1. Simple 400mV Series Reference

In applications where a reference potential greater than 0.4V is required, the simple addition of a feedback voltage divider programs the buffer op amp to provide gain. Figure 2 shows the typical connections for developing a reference voltage above 0.4V with the added feedback components. This configuration provides programmable reference voltages anywhere up to 0.35V below the supply potential used, the dropout voltage. Resistor  $R_G$  is chosen in the range from 10k to 100k to set the quiescent loading of the reference, then resistor  $R_F$  is simply selected for the required gain. While this illustration indicates fixed component values, the introduction of a variable element can provide a means of dynamically varying the reference output if desired. Figure 2 also shows additional input RC filtering which improves rejection of supply noise and a feedback capacitor that serves to both reduce noise gain and improve damping of the load response. The low operating current of the LT6650 and the input series resistor do not impair the low dropout performance significantly.

### Create a Virtual Ground for Unipolar Processing of Bidirectional Signals

The LT6650 often finds use in single supply data acquisition circuits where a low voltage offset is needed to provide a shifted “virtual ground.” Most ADC inputs can digitize right down to 0V input, but a single-supply input amplifier will not retain its accuracy at that low level, since

**LT**, LTC and LT are registered trademarks of Linear Technology Corporation. ThinSOT is a trademark of Linear Technology Corporation.

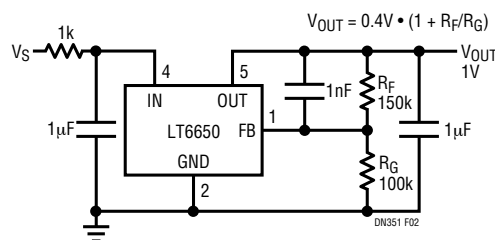
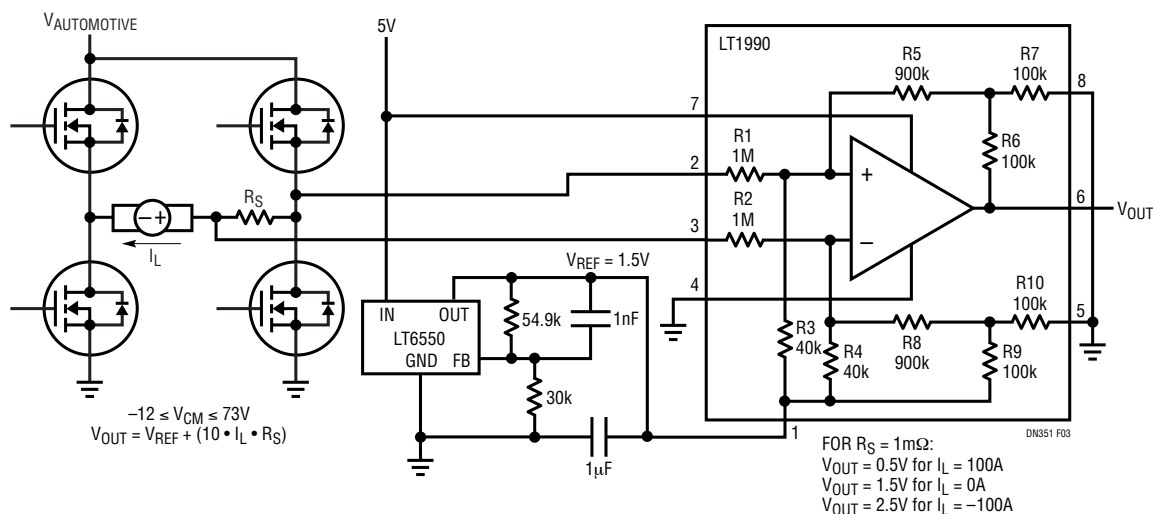

Figure 2. Typical Series Connection for Output Voltages Greater than 0.4V



**Figure 3. Offsetting a Bidirectional Signal for Unipolar Processing**

the output is “saturating” (even with rail-to-rail types). A design solution is to have a voltage reference circuit drive the REF port of input instrumentation amplifiers (IA), thereby introducing a controlled offset mapping that allows the ADC to accurately capture the “zero input” signal level, or even provide a controlled negative signal conversion range within a positive-only input window. Figure 3 shows a single supply powered LT1990 difference amp sensing a bidirectional motor current. The LT6650 reference is configured to provide an optimal REF input level for the circuit (1.5V in this example) which both establishes the working common mode input range and introduces an output offset that maps the desired bidirectional signal span into a single supply ADC conversion range. In high accuracy applications, the offset voltage itself may also be digitized so that software algorithms can accurately “auto-zero” the measurements. In multichannel data acquisition systems, a single LT6650 can generally provide offset signaling to an entire IA array.

### Shunt Mode Operation Works Like Precision Zener Diode

The LT6650 can easily be configured to behave much like a traditional Zener reference diode, but with far better regulation characteristics and the flexibility to be set to any voltage between 1.4V and 18V. This mode of operation allows the LT6650 to form simple negative references or other precision biasing functions. Figure 4 shows a simple negative reference circuit configuration. The programming is done just as with series mode operation,

only the load capacitor is increased in value to optimize transient response. The Zener “knee” of the shunt configuration is about 10 $\mu$ A (with  $R_G$  set to 100k) and accurate regulation to 200 $\mu$ A is provided.

### Conclusion

The LT6650 is an extremely flexible voltage control element, able to form accurate positive, negative or even floating reference voltages. With micropower operation over a wide 1.4V to 18V supply range and miniature ThinSOT packaging, the LT6650 offers design solutions for both portable and industrial applications. For single supply data-acquisition circuitry, the low 400mV output capability offers a simple virtual ground offsetting means that doesn’t unduly sacrifice dynamic range. Thanks to simple resistor-based programming, references of various arbitrary voltages may be produced using a single LT6650 bill-of-material item, thus reducing procurement and inventory costs.

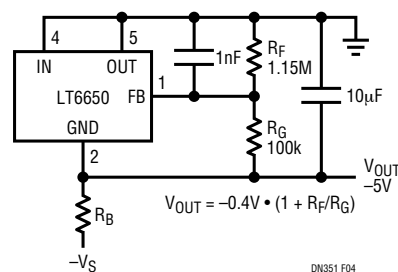

**Figure 4. Typical Configuration as -0.4V to -18V Shunt Reference**

### Data Sheet Download

<http://www.linear.com>

For applications help,  
call (408) 432-1900, Ext. 2525